

HAAPS

High Altitude Aeronautical Platforms

Affordable bandwidth will be as essential to the Information Revolution in the 21st century as inexpensive power was to the Industrial Revolution in the 18th and 19th centuries. Today's global communications infrastructures of landlines, cellular towers, and satellites are inadequately equipped to support the increasing worldwide demand for faster, better, and less expensive service. At a time when conventional ground and satellite systems are facing increasing obstacles and spiraling costs, a low cost solution is being advocated.

This paper focuses on airborne platforms- airships, planes, helicopters or some hybrid solutions which could operate at stratospheric altitudes for significant periods of time, be low cost and be capable of carrying sizable multipurpose communications payloads. This report briefly presents an overview about the internal architecture of a High Altitude Aeronautical Platform and the various HAAPS projects.

HAAPS

High Altitude Aeronautical Platform Stations (HAAPS) is the name of a technology for providing wireless narrowband and broadband telecommunication services as well as broadcasting services with either airships or aircrafts. The HAAPS are operating at altitudes between 3 to 22 km. A HAPS shall be able to cover a service area of up to 1'000 km diameter, depending on the minimum elevation angle accepted from the user's location. The platforms may be airplanes or airships (essentially balloons) and may be manned or un-manned with autonomous operation coupled with remote control from the ground. While the term HAP may not have a rigid definition, we take it to mean a solar-powered and unmanned airplane or airship, capable of long endurance on-station –possibly several years.

Various types of platform options exist: SkyStation™, the Japanese Stratospheric Platform Project, the European Space Agency (ESA) and others suggest the use of airships/blimps/dirigibles. These will be stationed at 21km and are expected to remain aloft for about 5 years. Angel Technologies (HALO™), AeroVironment/ NASA (Helios) and the European Union (Heliplat) propose the use of high altitude long endurance aircraft. The aircraft are either engine or solar powered and are stationed at 16km (HALO) or 21km (Helios). Helios is expected to stay aloft for a minimum of 6 months whereas HALO will have 3 aircraft flying in 8-hour shifts. Platforms Wireless International is implementing a tethered aerostat situated at ~6km.

A high altitude telecommunication system comprises an airborne platform – typically at high atmospheric or stratospheric altitudes – with a telecommunications payload, and associated ground station telecommunications equipment. The combination of altitude, payload capability, and power supply capability makes it ideal to serve new and metropolitan areas with advanced telecommunications services such as broadband access and regional broadcasting. The opportunities for applications are virtually unlimited. The possibilities range from narrowband services such as paging and mobile voice to interactive broadband services such as multimedia and video conferencing. For future telecommunications operators such a platform could provide blanket coverage from day one with the added advantage of not being limited to a single service. Where little or unreliable infrastructure exists, traffic could be switched through air via the HAPS platform. Technically, the concept offers a solution to the propagation and rollout problems of terrestrial infrastructure and capacity and cost problems of satellite networks. Recent

developments in digital array antenna technology make it possible to construct 100+ cells from one platform. Linking and switching of traffic between multiple high altitude platforms, satellite networks and terrestrial gateways are also possible. Economically it provides the opportunity for developing countries to have satellite-like infrastructure without the funds flowing out of the country due to gateways and control stations located outside of these countries.

System Architecture and Parameters

General Architecture

A typical HAAP-based communications systems structure is shown .

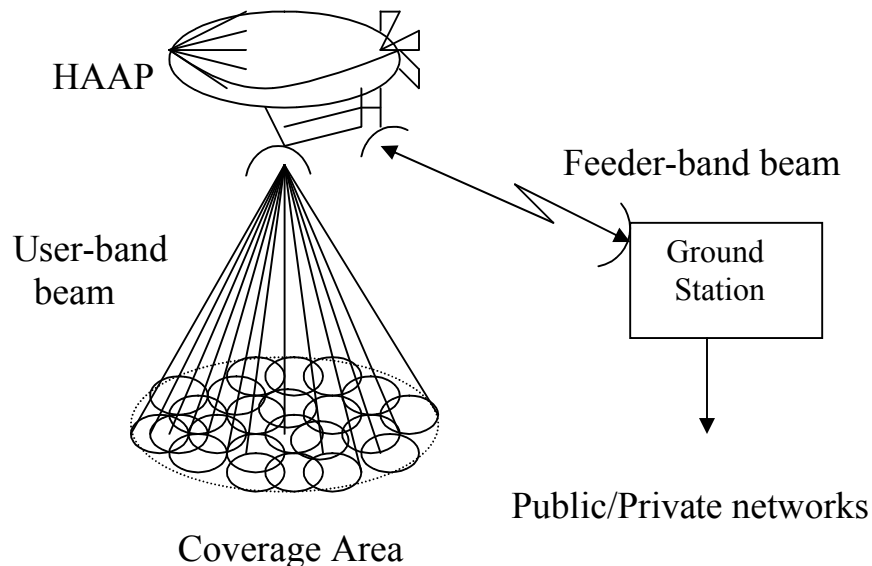

The platform is positioned above the coverage area. There are basically two types of HAAPS. Lighter-than air HAAPS are kept stationary, while airplane-based HAAPS are flown in a tight circle. For broadcast applications, a simple antenna beams signals to terminals on the ground. For individualized communication, such as telephony, "cells" are created on the ground by some beam forming technique in order to reuse channels for spatially separated users, as is done in cellular service. Beam forming can be as sophisticated as the use of phased-array antennas , or as straightforward as the use of lightweight, possible inflatable parabolic dishes with mechanical steering. In the case of a moving HAAP it would also be necessary to compensate motion by electronic or mechanical means in order to keep the cells stationary or to "hand off" connections between cells as is done in cellular telephony.

For a given platform altitude h , the diameter of the HAPS footprint can be computed using the formula:

$$d = 2R \cdot \left(\arccos \left(\frac{R}{R+h} \cdot \cos(\gamma) \right) - \gamma \right)$$

Equation leads to a minimum elevation angle of $\gamma = 15$ degrees for a footprint diameter of $d=152$ km and a minimum elevation angle of $\gamma = 0$ degrees for a footprint diameter of $d=1'033$ km (both at a platform altitude $h = 21$ km).

Onboard Equipment

Depending on the application, HAAP-based communications system could be implemented in many ways. A typical design will seek high reliability, low power consumption and minimum weight and size for the onboard portion of the system. That would lead to an architecture which places most of the system on the ground by limiting airborne components to a multichannel transponder, user-beam and feeder-beam antennas and associated antenna interfaces.

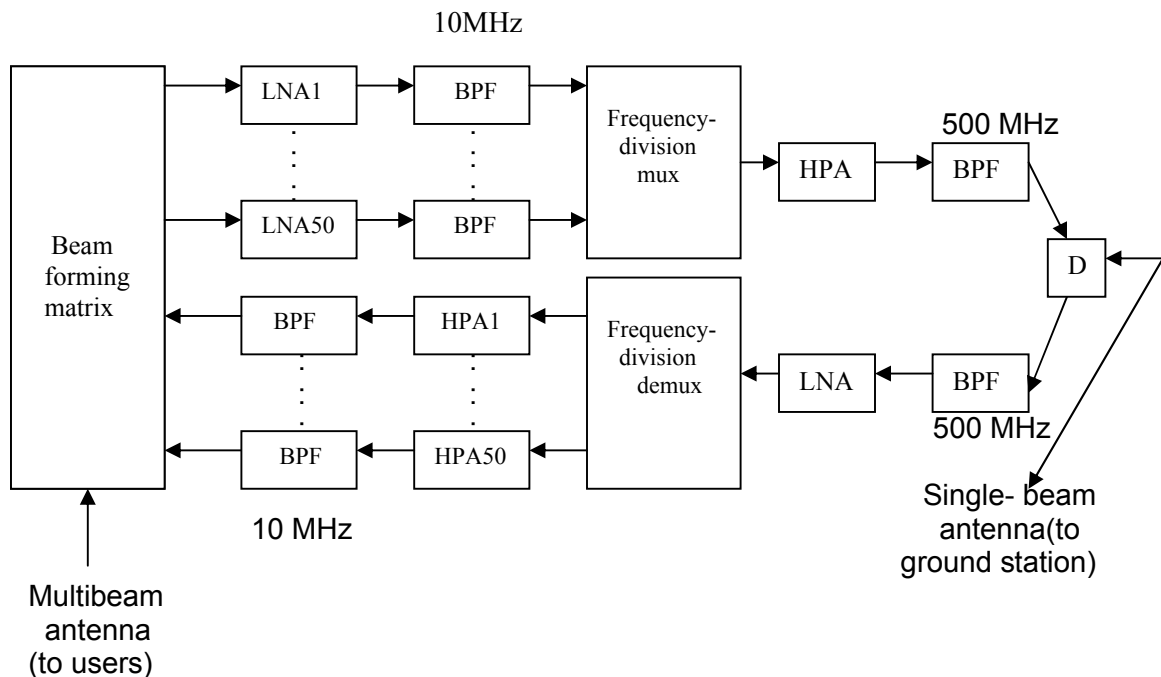

The figure shows a code-division multiple access (CDMA) system built around a standard satellite-like transponder bandwidth of 500 MHz. The transponder bandwidth can accommodate upto 50 antenna beams with 8 spread spectrum carriers/beam (assuming 1.25 MHz bandwidth). Carrier signals coming from a ground cell (ie., from a particular beam) and received by the onboard antenna are first amplified in low-noise amplifiers (LNAs). They are then limited to the standard 10 MHz bandwidth by band-pass filters (BPFs), and frequency division multiplexed. Before transmitting to the ground station, multiplexed signals are amplified in the high-power amplifier (HPA), BPFed to the transponder bandwidth and passed through the diplexer (D). Signal path in the opposite direction is similar and includes an additional demultiplexing stage. If commercial off-the-shelf equipment is to be used onboard, it will have to be placed in a chamber with climate and air-pressure control to prevent freezing, overheating (due to reduced heat convection) and dielectric breakdown.

Ground Installations

Communications between the HAAP and the ground would typically be concentrated into a single ground installation or perhaps into two locations for redundancy. There would be considerable advantage to collocating RF units, base stations and mobile switching centers(MSCs).

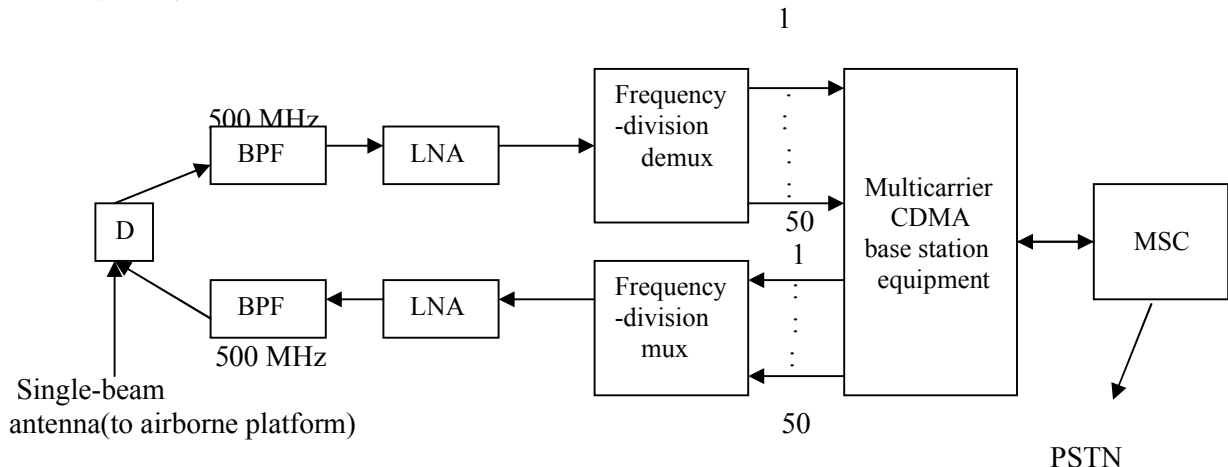

The ground system in figure corresponds to the onboard equipment from the previous figure. Carrier signals coming from the air-borne station are filtered by a BPF, amplified in LNAs, demultiplexed in the demux and passed to the CDMA base stations. In this case the base station consists only of a radio channel frame, since there is no need for power- amplifier and antenna-interface frames for every base station; a common wide band power amplifier and an antenna will serve all the collocated base stations. From the base stations, the signals are passed in the usual manner to the mobile MSC and public switched telephone network (PSTN). The return signal path towards the airborne station is similar except for the inverse multiplexing operation in the MUX and high power amplification by HPA.

Power System & Mission Requirements

Various power system components and mission requirements affect the sizing of a solar powered long endurance aircraft. The aircraft power system consists of photovoltaic cells and a regenerative fuel cell. for the power system, the greatest benefit can be gained by increasing the fuel cell specific energy.

Mission requirements also substantially affect the aircraft size. By limiting the time of year the aircraft is required to fly at high northern or southern latitudes a significant reduction in aircraft size or increase in payload capacity can be achieved.

Due to the high altitude at which these aircraft will be required to fly (20 km or higher) and the required endurance (from a few weeks to a year) the method of propulsion is the major design factor in the ability to construct the aircraft. One method of supplying power for this type of aircraft is to use solar photovoltaic (PV) cells coupled with a regenerative fuel cell. The main advantages to this method over others such as open cycle combustion engines or air breathing fuel cells is that it eliminates the need to carry fuel and to extract and compress air at altitude which can be a significant problem both in gathering the required volume of air and in rejecting the heat of compression.

In order for a solar powered aircraft to be capable of continuous flight, enough energy must be collected and stored during the day to both power the aircraft and to enable the aircraft to fly throughout the night. The propulsion system consists of an electric motor, gear box and propeller. The aircraft with amorphous silicon cells performed better than the CLEFT GaAs powered aircraft at lower aspect ratios and both amorphous silicon and CLEFT GaAs performed significantly better than the GaAs/Ge and silicon powered aircraft. As the efficiency increases, the corresponding reduction in aircraft size decreases. Fuel cell performance has a significant impact on size and performance of a solar powered aircraft. There are modest size reductions with increasing fuel cell efficiency; however, the size reductions which are gained by an increase in the specific energy of the fuel cell are substantial.

Aircraft size increases significantly with increasing altitude. The specified time of year (date) and latitude determines the charge/discharge period for the energy storage system as well as the amount of total solar energy available. The winter solstice, December 22, is the date with the longest discharge period and smallest amount of available solar energy. This date was chosen as the baseline because it is the time of lowest daily average solar flux in the northern hemisphere and therefore represents a worst case situation. Any aircraft power system and mission configuration which is feasible at this date would be capable of operating throughout the year. However, by varying the required latitude throughout the year, aircraft size can be reduced.

Payload and payload power required also has an effect on the aircraft size. Mission requirements will mostly determine the amount and type of payload. In most situations lightweight, low power instruments, similar to satellite equipment, will need to be used.

If very light weight amorphous silicon arrays or any thin film array of similar performance can be mass produced, they would have significant advantages over individual-celled rigid arrays. The main advantage would be their incorporation onto the wings of the aircraft. Since they are flexible and can be made in large sheets they can conform to the shape of the wing. This allows for fairly easy installation directly over the wing surface. Also there would be no need to wire each individual cell together as is necessary with individual rigid cells. In order to make the commercial construction and maintenance of this type of aircraft practical, light weight, flexible PV arrays will need to be used.

HAAP-BASED COMMUNICATIONS SYSTEM PERFORMANCE

One of the most attractive features of an airborne platform-based wireless system is its very favourable path-loss characteristic relative to either terrestrial or satellite systems.

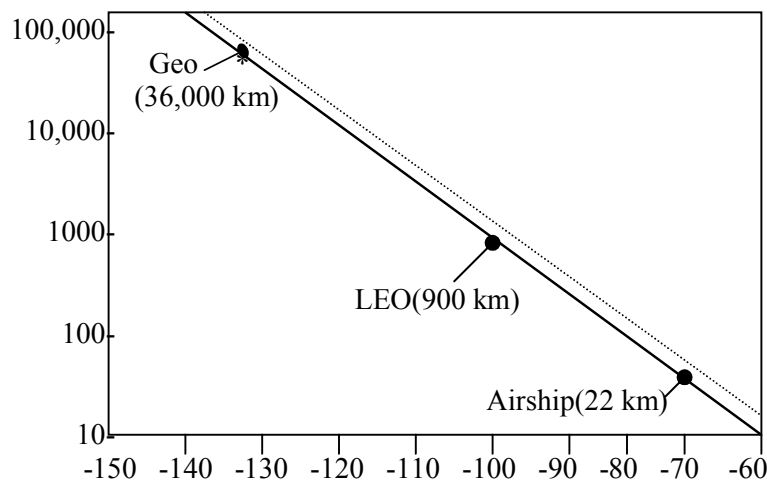

A typical path loss vs. distance is shown for terrestrial and non-terrestrial systems. For non-terrestrial systems, free space path loss is inversely proportional to square of distance. In terrestrial systems, path loss is a stochastic variable (often determined empirically) and ratio is $1/r^4$. The more favourable propagation characteristics in satellite systems are offset by the great distance. Even LEO distances cause path losses comparable to those in a relatively large terrestrial cell: path loss to a LEO at 900 km altitude equal to path loss along ground at 10 km. An airship at 22 km altitude to a point on ground directly below it, path loss is same as at the edge of a relatively small terrestrial system cell with approximately 2km radius.

The energy budget of the user link in an airborne-based system is enhanced by Ricean and not Rayleigh type fading and high gain platform antennas. Therefore, the system can operate with conventional cellular/PCS handsets and relatively simple onboard equipment. The power requirements of the onboard equipment are within limits of the onboard amplifier and power supply.

Figure shows coverage of terrestrial and HAAP-based systems.

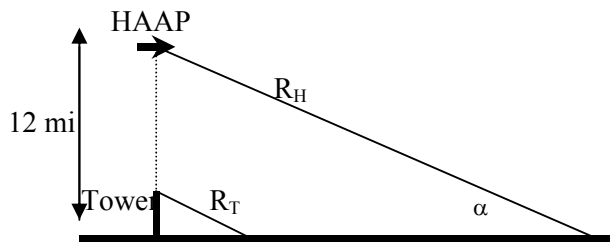

The antenna gain in terrestrial systems is $G_T = 10-17\text{dB}$ while an airborne antenna gain is $G_H = 30-35\text{ dB}$.

For a terrestrial and a HAAP based system to maintain the same quality of service, the Signal to noise ratio should be the same at the edge of their respective coverage areas.

$$\text{SNR} \propto (P \times G) / R^n$$

P- transmitter power , G- antenna gain

N- path loss exponent has values 2 to 5. In free space propagation, $n=2$, in suburban type, $n=3.84$ and in highly urban, $n= 5$.

$$\text{HAAP transmitter power, } P_H = (G_T R_H^2) P_T / (G_H R_T^n)$$

HAAP based telephone systems would avoid the cost of communication links required to connect geographically dispersed base stations that are required in terrestrial systems. This centralized architecture can also result in improved efficiency of channel realization- a large trunk being more efficient than multiple smaller ones. If a HAAP based system is used to provide cellular coverage, the total offered load is served by a central facility. The no: of channels do not have to be dimensioned according to busy hour traffic but to average traffic in the area, since all available channels can be shared among all the cells and local traffic peaks are smoothed out. In a HAAPS-based system the no: of channels required to cover the entire area is less than that of terrestrial systems and therefore lesser no: of base stations.

The CDMA capacity can be increased by improving the accuracy of the power control algorithm. Two main factors influence errors in power control- the dynamic range of signal attenuation and distribution of fast fades. Both are reduced in HAAPS-based system. In terrestrial call dynamic range of signal attenuation is 69-80dB while it is 12-22 dB in HAAPS. The Ricean distribution of fades in HAAPS system yields an additional energy gain which is a function the Recian factor.

Comparison Of Wireless Systems

The high-altitude platforms have many of the advantages of both terrestrial and satellite systems, while at the same time avoiding many of their pitfalls.

Issue	Terrestrial Wireless	Satellite	High-Altitude Platform
Availability and cost of mobile terminals	Huge cellular/PCS market drives high volumes resulting in small, low-cost , low-power units.	Specialized, more stringent requirements lead to expensive.	Terrestrial terminals applicable.
Propagation delay	Not an issue	Causes noticeable impairment in voice communications in GEO (and MEO to some extent).	Not an issue
Health concerns with radio emissions from handsets	Low-power handsets minimize concerns.	High-power handsets due to large path losses(possibly alleviated by careful antenna design).	Power levels like in terrestrial systems(except for large coverage areas).
Communications technology risk	Mature technology and well-established industry.	Considerable new technology for LEOs and MEOs; GEOs still lag cellular/PCS in volume, cost and performance.	Terrestrial wireless technology, supplemented with spot-beam antennas; if widely deployed, opportunities for specialized equipment (scanning beams to follow traffic).
Deployment timing	Deployment can be staged; substantial initial build-out to provide sufficient coverage	Service cannot start before the entire system is deployed.	One platform and ground support typically enough for initial commercial service.
System growth	Cell-splitting to add capacity, requiring system reengineering; easy equipment update/repair.	System capacity increased only be adding satellites; hardware upgrade only with replacement satellite.	Capacity increase through spot-beam resizing and additional platforms; equipment upgrades relatively easy.

System complexity due to motion of components	Only user terminals are mobile.	Motion of LEOs and MEOs a major source of complexity, especially when intersatellite links are used.	Motion low to moderate(stability characteristics to be proven).
Operational complexity and cost	Well-understood	High for GEOs and especially LEOs due to continual launches to replace old or failed satellites.	Some proposals require frequent landings of platforms (to refuel or to rest pilots).
Radio channel "quality"	Rayleigh fading limits distance and data rate; path loss upto 50dB/decade; good signal quality through proper antenna placement.	Free-space-like channel with Ricean fading; path loss roughly 20dB/decade; GEO distance limits spectrum efficiency.	Free-space-like channel at distances comparable to terrestrial.
Indoor coverage	Substantial coverage achieved.	Generally not available(high power signals in Iridium to trigger ringing only for incoming calls).	Substantial coverage possible.
Breadth of geographical coverage	A few kilometers per base station.	Large regions in GEO; global for LEO and MEO.	Hundreds of kilometers per platform.
Shadowing from terrain	Causes gaps in coverage; requires additional equipment.	Problem only at low look angles.	Similar to satellites.
Communications and power infrastructure; real estate	Numerous base stations to be sited, powered and linked by cabled or microwave.	Single gateway collects traffic from a large area.	Comparable to satellite.
Esthetic issues and health concerns with towers and antennas	Many sites requires for coverage and capacity; "smart" antennas make them more visible; continued public debates expected.	Earth stations located away from populated areas.	Similar to satellites.
Public safety concern about flying objects	Not an issue.	Occasional concern about space junk falling to Earth.	Large craft floating or flying overhead can raise significant objections.
Height over ground level	5 ... 250 m	500 ... 36'000 km	3 ... 22 km 16 ... 19 km

Lifetime	up to 15 years	up to 15 years	up to 5 years
Capacity	high	low	medium
Orbit		geostationary only on equatorial plane or non-geostationary	“geostationary” anywhere on the world
Coverage	only land and shore possible	land and sea possible	land and sea possible
Fade margin	High	Low	Medium
Indoor reception	Possible	Not possible	? ?
Remarks	Maintenance possible High number of transmitters necessary Well known and proven technologies	High launching costs Well known and proven technologies	Maintenance and re-deployment possible Unsolved power problems

Various HAAPS Projects

HAPS have been proposed using both airship technology and high altitude aircraft.

Airship Technologies

The idea is to keep unmanned Zeppelin-like balloons geostationary at an altitude of 3 km to 22km. Each HAPS shall provide mobile and fixed telecommunication services to an area of about 50 km to 1'000 km diameter, depending on the minimum elevation angle accepted from the user's location. To provide sufficient capacity in such large areas, spot beams have to be foreseen. One of the main challenges is to keep the platforms stationary. Winds of up to 55 m/s can occur at these altitudes.

1.Sky Station

Sky Station is the name of an airship system planned by the US company “Sky Station International”. The number of platforms will depend on the demand (250 platforms are announced). The balloons will be covered with solar cells, giving energy to the electrical motors. The data rates foreseen for the fixed services are 2 Mbps for the uplink and 10 Mbps for the downlink. The data rates foreseen for the mobile services are 9.6 - 16 kbps for voice and 384 kbps for data. The cost of the entire project for a worldwide broadband infrastructure is estimated at \$2.5 billion. The start of the service is now postponed to 2002. For a later phase, radio links inter-connecting the different platforms are planned.

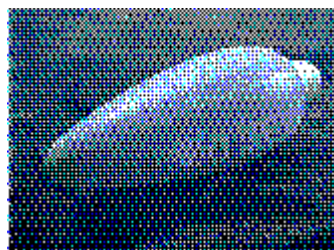

Initially, Sky Station intended to use ion engines for the steering of the platforms. Very little published information is available on this technology. The feasibility of sufficiently powerful and efficient ion engines has created a lot of debate [5]. In any case, Sky Station has apparently chosen to use conventional electric motors and lightweight propellers, instead. More details of the propulsion engines are not yet publicly available.

2.StratSat

StratSat is an airship system planned by the UK based company “Advanced Technology Group(ATG)”. With both civilian and military applications, the StratSat cost effective and safe solution for geo-stationary telecommunications payloads above large customer concentrations. The airship in the stratosphere is well above conventional air traffic and presents no threat. Its cheap launch costs, compared to the conventional satellites allows those in the industry to talk of reducing the cost of calls from a mobile telephone, by an order of magnitude, thereby capturing a high proportion of the market.

The solar array provides the sole source of renewable energy for the airship. The array is placed over the upper quarter of the hull and extends over approximately three-quarters of the

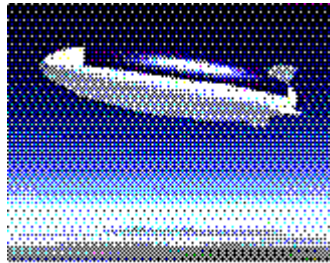

length of the craft. The array can be realigned to the daily sun location/angle by the roll rotation of the whole airship. The airship is propelled and steered by means of a 'Contra-Rotating Coned Rotor' mounted on a tailcone at the rear of the envelope, as part of a compound propulsion system. This unit provides longitudinal thrust (to counter the prevailing stratospheric winds) and lateral force (for maneuvering) to enable the airship to hold station within a 1 km cube.

3.Stratospheric Platform System from Japan

The Wireless Innovation Systems Group of the Yokosuka Radio Communications Research Center in Japan .The airship has a semi-rigid hull of ellipsoidal shape with an overall length of nearly 200 m. It is composed of an air-pressurized hull for maintaining a fixed contour, and internal bags filled with the buoyant helium gas. Two air ballonets are installed inside the hull to keep the airship at a required altitude. For a load balance to the lifting force, catenary curtains are connected to a lower rigid keel, directly attached to the envelope. Propulsive propellers are mounted on both the stem and stern of the airship, and tail wings are installed on the rear end of the hull. A solar photovoltaic power subsystem of solar cells and regenerative fuel cells is provided to supply a day/night cycle of electricity for airship propulsion

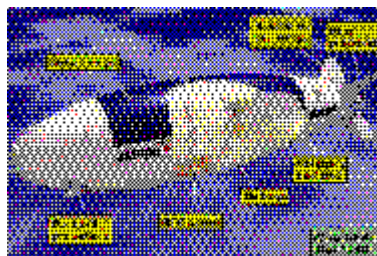

4.ARC System

The Airborne Relay Communications (ARC) System is the name of an airship platform planned by the US company Platforms Wireless International. The ARC system is designed to operate at lower altitudes, 3 to 10.5 km. Originally known as “Aerostats”, these airships were designed as airborne defense platforms for low-level radar use. Inspired by the dirigibles that monitor the border between the US and Mexico, Platforms Wireless International develops a system which shall provide fixed-wireless broadband as well as mobile services to areas of 55 to 225 km diameter per system and servicing up to 1'500'000 subscribers (depending on system configuration and antenna projection power).



An ARC airship is a 46 m long helium-filled balloon, which can carry almost 700 kg of payload. An airship configuration is designed with two supporting aircrafts, which will be deployed to ensure uninterrupted service coverage when severe weather conditions (winds in excess of 145 km/h) or monthly servicing require the temporary docking of the airship.

Unlike the three stratospheric platform stations described above, the ARC system is not using solar cells. Electricity is supplied to the payload via a 2.5 cm thick cable. It also incorporates a fibre-optic cable link that connects the airborne base stations to the rest of the network. A “no-fly zone” must also be created so other aircrafts do not fly into the airship or its cable.

Aircraft Technologies

Although the commercial applications are only starting now to appear, the topic of communication using an aircraft is not new. Airplanes have been used to broadcast TV over Vietnam from 1966 to 1972. High Altitude Aircrafts will operate at an altitude of 16 km to 19 km, high above commercial airline traffic and adverse weather.

1.HALO-Proteus

Angel Technology Corporation (USA) is planning to offer broadband telecommunication service using manned aircraft . A piloted, FAA-certified High Altitude Long Operation (HALO) aircraft will provide the “hub” of the network. Operating continuously over each market in three eight hours shifts.

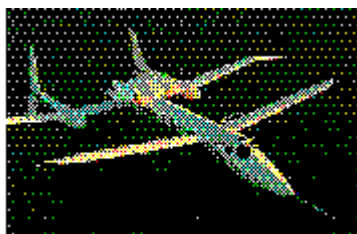

Consumers will be able to access video, data, and the Internet at rates ranging from 1 to 5 Mbps. The technology of high altitude manned aircraft is mature. A broadband wireless link at 52 Mbps has been demonstrated in August 1998.

2. SkyTower

Through funding support from NASA, AeroVironment has developed an unmanned, solar-electric airplane called Helios which will be capable of continuous flight for up to six months or more at 60,000 feet in the stratosphere, above the weather and commercial air traffic (AeroVironment also developed Pathfinder Plus, Helios' predecessor). Helios will provide a telecommunications platform from this position in the stratosphere, acting as an 11-mile tall tower— hence the name “SkyTower” . AeroVironment officially formed SkyTower, Inc. in October 2000 to pursue commercial telecom opportunities enabled by AeroVironment's



proprietary solar-electric aircraft technology.

SkyTower's stratospheric communications networks are comprised of airborne segments (or payloads) which communicate with user terminals and gateway stations on the ground. The ground gateway stations will serve as an intermediate interface between the aircraft and existing Internet and PSTN connecting systems. When a signal passes from the end users up to the airplane and then from the airplane to the ground gateway antenna, a ground switching router will determine whether the data should be directed to the Internet, a private data network, or the telephone network. These interactive network systems are being designed to maximize the overall throughput of the network. Fixed wireless broadband total throughput is projected to be approximately 10 to 20 Gbps per platform with typical user transmission speeds of 1.5 Mbps or higher (125 Mbps is feasible for a single user).

3. AVCS

General Atomics, a USA - San Diego based manufacturer of Unmanned Aerial Vehicles (UAV), is developing an Aerial Vehicle Communications System, AVCS .Figure 7 shows the system architecture of AVCS.

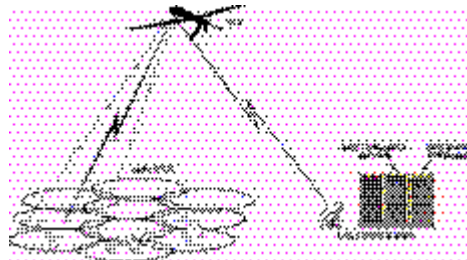

No further information on AVCS (press releases or articles) could be found on the internet, apart from the official web site.

4. Heliplat

The Heliplat (HELios PLATform) is being designed at Politecnico di Torino under an ASI (Italian Space Agency) grant. Heliplat is an unmanned platform with solar cell propulsion, which will be operated in the stratosphere. It will enable a payload of about 100 kg, and offers an available power of some hundreds watt. The present research proposal is devoted to the study of

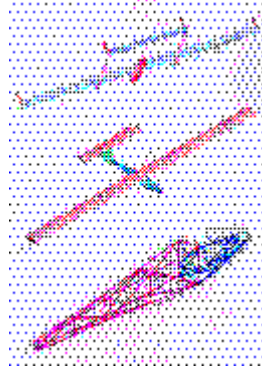

possible applications of such a platform, not only for cellular/personal communications, but also for localization and surveillance. The use of the platform as base station (GSM or UMTS) can provide cellular telephony service to rural areas with low user density, because large diameter cells can be easily implemented; to increase the capacity of the public switched network in case of natural disaster, easily moving the platform if needed; to provide reliable telecommunication services to the ships sailing transoceanic courses, using networks of aerial platforms placed on the most important navigation lanes. The project is at an early stage (see Figure 8).

Frequencies

WRC-97 has already designated in Resolution 122 a pair of 300 MHz frequency bands around 47 GHz (downlink: 47.2 - 47.5 GHz and uplink: 47.9 - 48.2 GHz) for the fixed services (FS) of high-altitude platform stations (HAPS). Due to the higher rain attenuation in certain areas, WRC-2000 proposed to study an additional frequency allocation for HAPS between 18 and 32 GHz for ITU-R Region 3 (Asia), focussing particularly, but not exclusively, on the bands 27.5 - 28.35 GHz and 31.0 - 31.3 GHz . Studies have been started within ITU-R to achieve the most efficient use of the spectrum and to define the technical sharing criteria.

It must be noted that the FS (Fixed Service) is under national responsibility and that also the operation of such an aircraft requires the authorization from the local aviation administrations.

Advantages

HAPS do not require any launch vehicle, they can move under their own power throughout the world or remain stationary, and they can be brought down to earth, refurbished and re-deployed. Once a platform is in position, it can immediately begin delivering service to its service area without the need to deploy a global infrastructure or constellation of platforms to operate. HAPS

can use conventional base station technology - the only difference is the antenna. Furthermore, customers will not have to use different handsets.

The relatively low altitudes enable the HAPS systems to provide a higher frequency reuse and thus higher capacity than satellite systems. The low launching costs and the possibility to repair the platforms gateway could lead to cheap wireless infrastructures per subscriber. Joint venture companies and government authorities located in each country will control the Sky Station platforms serving their region to ensure the best service offerings tailored to the local market. Offerings can change as a region develops. Each platform can be retrieved, updated, and re-launched without service interruption. Sky Station platforms are environmentally friendly. They are powered by solar technology and non-polluting fuel cells. The relatively low altitudes - compared to satellite systems - provide subscribers with short paths through the atmosphere and unobstructed line-of-sight to the platform. With small antennas and low power requirements, the HAPS systems are suited for a wide variety of fixed and portable user terminals to meet almost any service needed. Since most communication equipment are located in the ground station, system administration will be easier than for typical dispersed terrestrial systems. The single origin of the HAAP's beams that form coverage cells on the ground opens up the potential for flexible call configuration with onboard programmability- a process that is much easier than splitting a terrestrial cell and redesigning radio patterns to accommodate growth in terrestrial cellular systems. The fixed location of the HAAPs could be advantageous for situations where end-user radios on the ground use directional antennas that are pointed to the signal source as in a wireless local access system. Here the end-user radios can be reassigned to different cells (beams) without having to redirect their antennas.

Applications

The large coverage area of a HAAP would tend to give it an advantage in two types of applications.

One is where many widely separated customers receive the same communication as in entertainment broadcasting. HAAP technology might be able to achieve many of the benefits of the GEO-based Direct Broadcast Satellite without having to transmit quite so homogeneously over so large an area. Unlike GEO-based technology, upstream channels are also possible in HAAPs which would enable interactive TV and Internet access capabilities.

The other type of application in which a HAAP's large coverage area ought to be advantageous is in telecommunications for areas having a low density of customers, especially when prospective customer's specific geographic locations are unknown. The cost per customer of installing fixed facilities such as wire increases with decreasing customer density. Even though cellular, PCS and wireless systems do not depend on traffic density, cost per subscriber rises when the traffic density gets so low that many underutilized base stations have to be installed to achieve geographic coverage. Here both satellites and HAAPs come into play. Eventhough satellites are more advantageous at times, HAAPs provide a large coverage area along with indoor signal penetration. HAAPs at the same time uses much of the same equipment as terrestrial systems.

A single HAAP's coverage area of 100 km would cover a metropolitan city and in such cases, it is used to support commercial services and advertising with lesser time and investment.

HAAPs would eliminate high visible antenna towers that sometimes cause public resistance to terrestrial systems.

HAAPs give better signal quality and fewer "holes" in radio coverage. But in tunnels and deep basements, coverage requires repeaters or macrocells.

A HAAP system with a coverage area with a look angle of 15 degree will give a line of sight communication. Thus the higher frequencies such as LMDS, 38GHz, 47GHz and so on can be utilized for very wide band internet access, entertainment video and audio and videoconferencing.

HAAPs technology because it can be made to cover large areas quickly without having to rely on facilities in the service area could be suited to applications that are temporary or limited.

Examples of such services would be coverage for onetime seasonal vents, services for remote areas, temporary services in natural disasters or emergencies.

Ring-shaped clustering simplifies the design of steerable multibeam antennas - Traditional arrangement of cells in a hexagonal pattern covering the plane is how wireless coverage is provided in terrestrial systems. But when coverage is established from an antenna mount on a circling plane or an airship rotating around its central axis due to stratospheric winds, the "natural" cell shape is a geometric pattern invariant to such platform movements. Such coverage is made up of a set of concentric rings. This arrangement is possible since cell shapes and their relative positions are of no consequence to the operations of a cellular system and has certain advantages over traditional pattern. Here each cell has just one or two neighbours which simplifies hand off algorithms.

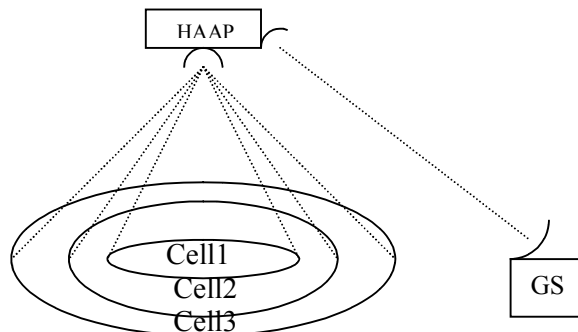

Cell scanning eliminates complex airborne antennas and saves power by focusing on smaller areas: -

The HAAP takes advantage of the "smart antenna" systems. Compared to the terrestrial system in which sectorized antennas sent and receive radio waves travelling along the ground, the HAAPs favourable "look angle" means that its energy can be readily focused onto a confined area..

Depending on the application, the beam can visit a particular cell at regular or irregular intervals. Regular visits are suitable for real time applications and services to meet quality-of-service criteria like delay and delay variance. Random timed between visits can be used in non-time-critical applications such as internet access.

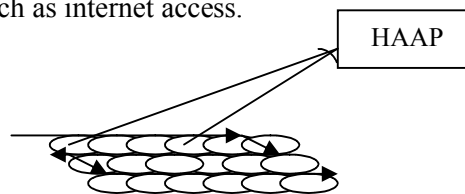

While the beam is pointing to one of the cells, information is exchanged between user terminals and the communications equipment on the platform: the traffic intended for that cell is buffered in the interval between successive beam visits and then beamed down in a burst manner: likewise information in user terminal is buffered until the control signal from the platform indicates that the beam is pointing to the cell, triggering the beaming up of information bursts. If one beam is not enough to satisfy the capacity or delay requirements, two or more beams can be used to scan the cells in a staggered manner. A variant of this approach is a system in which beams have different roles "scout" beams scan the cells in search of those in which there are data ready to send in user terminals; "traffic" beams visit only the cell marked by "scout" beams either randomly or according to some priority mechanism.

Stratospheric radio-relay maritime communications system:-

Providing high quality telecommunications services including voice and data transmissions for maritime vessels crossing world oceans is one of the most complex problems in telecommunication engg. Now, only GEO satellite system provide multichannel, long distance, reliable maritime commercial communication services. But due to bulky size of maritime satellite user terminals, satellite based service is expensive. The HAAPs concept can solve this problem for many large world ocean shipping lanes. Chains of HAAPs positioned above these lanes would operate as stratospheric radio-relay links, terminated by coastal radio centers at each end of the transoceanic link. Operating frequencies for user, feeder and inter-HAAP links are in the bands commonly used in satellite systems. The system can provide multichannel, reliable, cost-efficient Maritime communication service, including voice, data, video, paging and broadcasting. Platforms can either be stationary or it may move at very low speeds along a race-like path with endpoints close to land-based gateways.

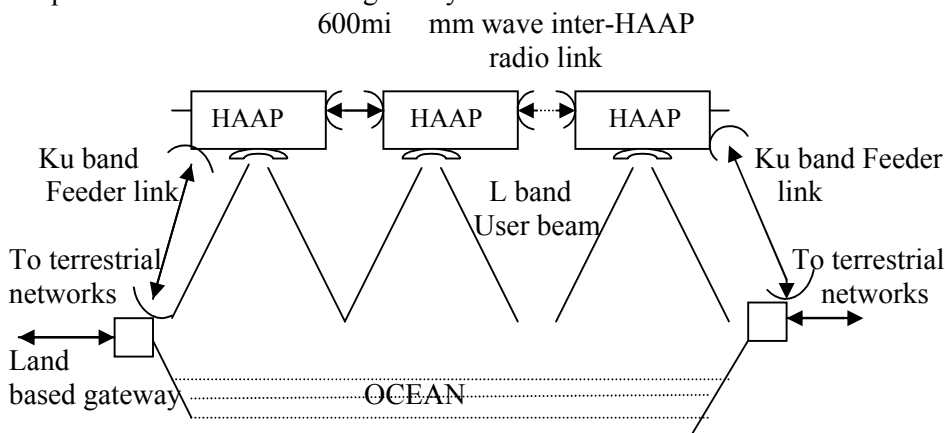

HAAP Issues

In spite of many advantages there are many critical issues that the HAAPs technology is facing. The most critical issue is that- it still remains to be demonstrated that placing a platform at stratospheric altitude and "fixing" it reliably above the coverage area is possible and that it can be done in a cost-efficient, safe and sustained manner.

It is still not proven that planes can fly at stratospheric altitudes for long stretches of time, that dirigibles can be stationed at stratospheric altitude, and that the position of weather balloons can be controlled.

Another critical issue is the presence of winds in the stratosphere. The average minimum stratospheric wind velocity is 30-40m/s and occurs between 65 000 and 75 000ft depending on latitude. Eventhough HAAPs are designed to withstand these winds it may not be able to withstand sudden wind gusts resulting in temporary or total loss of communication. The instantaneous power P needed to counter the wind force exerted on airship is

$$P=1/2\rho C_d S_c v^3$$

Where ρ is the air density, C_d is the drag coefficient , S_c the airship cross sectional area and v , instantaneous wind velocity. The wind direction remains steady in this layer for most of the year except for a twice yearly change of 180degree.

The technical problems are still substantial:

All materials must be lightweight, resistant to radiance at high altitudes, and at least for airships leakproof for helium.

The engines must be strong enough to keep the platforms stationary at winds of up to 55 m/s. Flying with solar power is a possible solution. Airships especially offer enough area on their envelope for the integration of solar cells. For long endurance missions only part of the collected irradiance is available for the direct propulsion. The rest has to be used to charge the energy storage for the night time. Sufficient energy has to be produced and stored for the propulsion and the telecommunication equipment.